

# THERMOPLASTIC SCREED BOX WITH RIB FUNCTION

The screed box can apply flat lines, long flex, and ribs over a line on line in one pass. The Borum thermoplastic screed box is available in the following widths: 10, 12, 15, 20 cm.

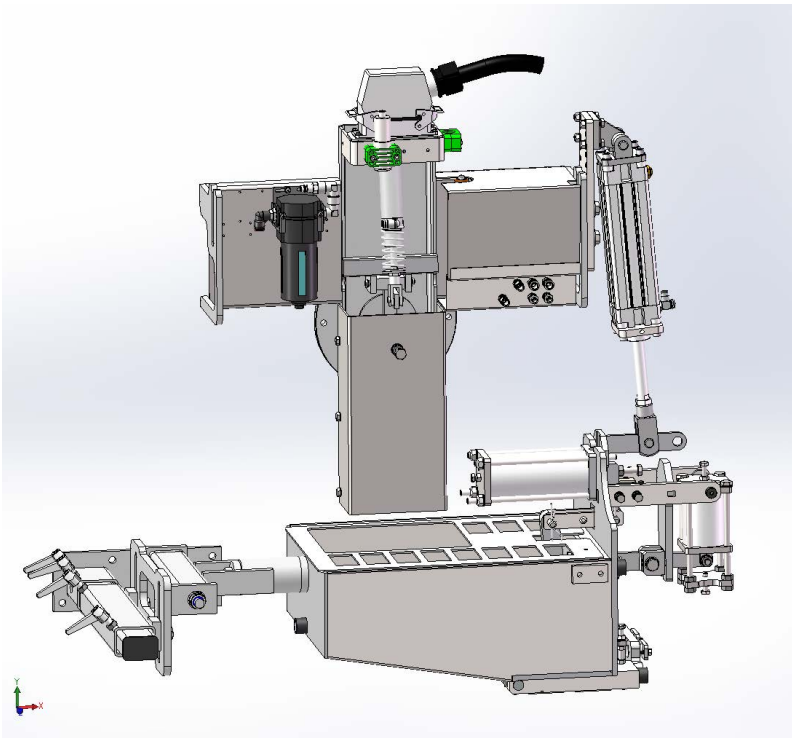

## LINE TYPES



Flat line



Interrupted flat line



Long flex



Ribs over line

With this type of screed application, the box is dragged with constant contact to the surface. The contact points determine the line width. The material pressure is by gravity only and this is how the material is poured in the marking box. The material coming out of the box will fill up any holes, pores, or other types of road imperfections. This means that material consumption will depend on the road surface.

The screed box equipment is mounted directly on the side of the chassis.

The equipment is constructed with one main application box. If you do not need to switch the line widths often, you have the option to only change the application opening based on your width requirements instead of the whole box! This makes the application equipment more cost-efficient!

The Borum thermoplastic screed box is available in the following widths: 10, 12, 15, 20, and 30 cm. Other sizes available upon request.

The thickness for application of flat lines is usually between 2 - 4 mm.

## RIB LINE FUNCTION

The screed box is also equipped with a rib function. This allows you to apply ribs over a line in one pass. The total height of line with rib is usually between 8 to 15 mm depending on the material. The lines are recommended to be as thin as possible when combined with ribs (approx. 1,5 - 2 mm).

The usual application speed for applying ribs over a flat line is 1-3 km/h, while for screed application of flat lines it is up to 5 km/h.

## LASER SENSOR FOR MEASURING AND REFILLING MATERIAL

The equipment is also supplied with a laser that constantly measures the material level in the application box. If the material level becomes lower than 50%, the application box will be automatically refilled.