



THERMOPLASTIC PREHEATERS

TECHNICAL NOTE

Borum thermoplastic preheaters are melting, heating and mixing the thermoplastic material making it ready for application via the road marking machine. To ensure a continuously road marking process it is important to choose the proper size of the preheater.

REVISION-002

PREHEATERS - THE WORKING PRINCIPLE

Preheaters are designed in two different systems:

- **Direct heating (D):** The thermoplastic material is heated directly from the burner

Standard capacities: 300 L, 500 L, 750 L, 1000 L (1320 lb wt, 2200 lb wt, 3300 lb wt, 4400 lb wt.)

- **Indirect heating (ID):** The thermoplastic material is heated via thermal transfer oil in a separate chamber heated by the burner

Standard capacities: 250 L, 400 L, 600 L, 800 L, 1100 L, 1600 L, 2500 L (1100 lb wt, 1760 lb wt, 2640 lb wt, 4840 lb wt, 7040 lb wt, 11000 lb wt)



The burner is powered either by diesel oil or propane gas. However, the version we can see is most popular on the market is with diesel burners. Diesel has the advantage that it is not considered as dangerous goods when transported on a truck. Furthermore, it is easier to handle and refill diesel in a fuel tank than exchanging the propane tanks for the gas burner.

The preheaters are **also supplied with a thermostat** for thermoplastic material temperatures from +50 °C to 230 °C. This includes an **integrated display showing actual thermoplastic temperature.**

CHOOSING THE OPTIMAL PREHEATER CAPACITY

To ensure a continuously road marking process it is important to choose the proper size of the preheater. This is done by calculating the material consumption of the road marking machine from the following factors:

- Speed of the machine in km/h (mph)
- Marking amount per day
- Mass of the road marking material calculated from marking width, pattern, thickness and density of thermoplastic $\rho \sim 2 \text{ kg/litre (2 lbs/lb wt)}$

A rule of thumb indicates the total preheater volume must be minimum four times the tank capacity of the marking machine; e.g. for a BM 3000 T machine with a material capacity of 445 L it is advised to have minimum preheater size of 4 X 445 litres (4 x 979 lb wt).

Please address Borum for advice for selecting preheaters.



SPECIFICATIONS

Tank type	Dimension LxWxH (mm)	Weight dry, kg	Heat transmission oil, kg	Burner output kW	Hydraulic for agitator at 30 rpm	
					L/min	Max bar
BM D preheater						
BM D 300	1500x1060x1570	655		24	11	85
BM D 500	1580x1130x1720	710		38	11	85
BM D 750	1580x1130x2120	900		38	11	85
BM D 750 x 2	1580x2280x2120	1840		2x38	22	85
BM D 1000	1630x1180x2320	1050		47	11	85
BM D 1000 x 2	1630x2380x2320	2140		2x47	22	85
BM ID preheater						
BM ID 250	1470x1060x1570	700	30	24	11	85
BM ID 400	1560x1130x1720	820	53	38	11	85
BM ID 400 x 2	1560x2280x1720	1650	106	2x38	22	85
BM ID 600	1560x1130x2030	1000	75	38	11	85
BM ID 600 x 2	1560x2280x2030	2010	150	2x38	22	85
BM ID 800	1610x1180x2220	1120	86	47	11	85
BM ID 800 x 2	1610x2380x2220	2250	172	2x47	22	85
BM ID 1100	1670x1250x2380	1650	124	47	11	190
BM ID 1100 x 2	1670x2520x2380	3310	248	2x47	22	190
BM ID 1600	2160x1730x2130	2800	277	56	11	190
BM ID 2500	2290x1830x2520	2900	263	70	17	140

Loading capacity: The number indicates the volume size of the preheater measured in litres, e.g. ID 600 has a capacity of 600 litre (1320 lb wt) thermoplastic equivalents to ~1200 kg (2645 lbs).

INDIRECT HEATING VIA THERMAL OIL

The thermoplastic material is heated via thermal transfer oil in a separate chamber heated by the burner. The oil chamber is found in the preheater's side walls. Therefore, the heating of the thermoplastic material is done from various angles due to the oil chambers surrounding the preheater. This is different compared to the direct heating system where the heating is done from one location - the bottom of the preheater.

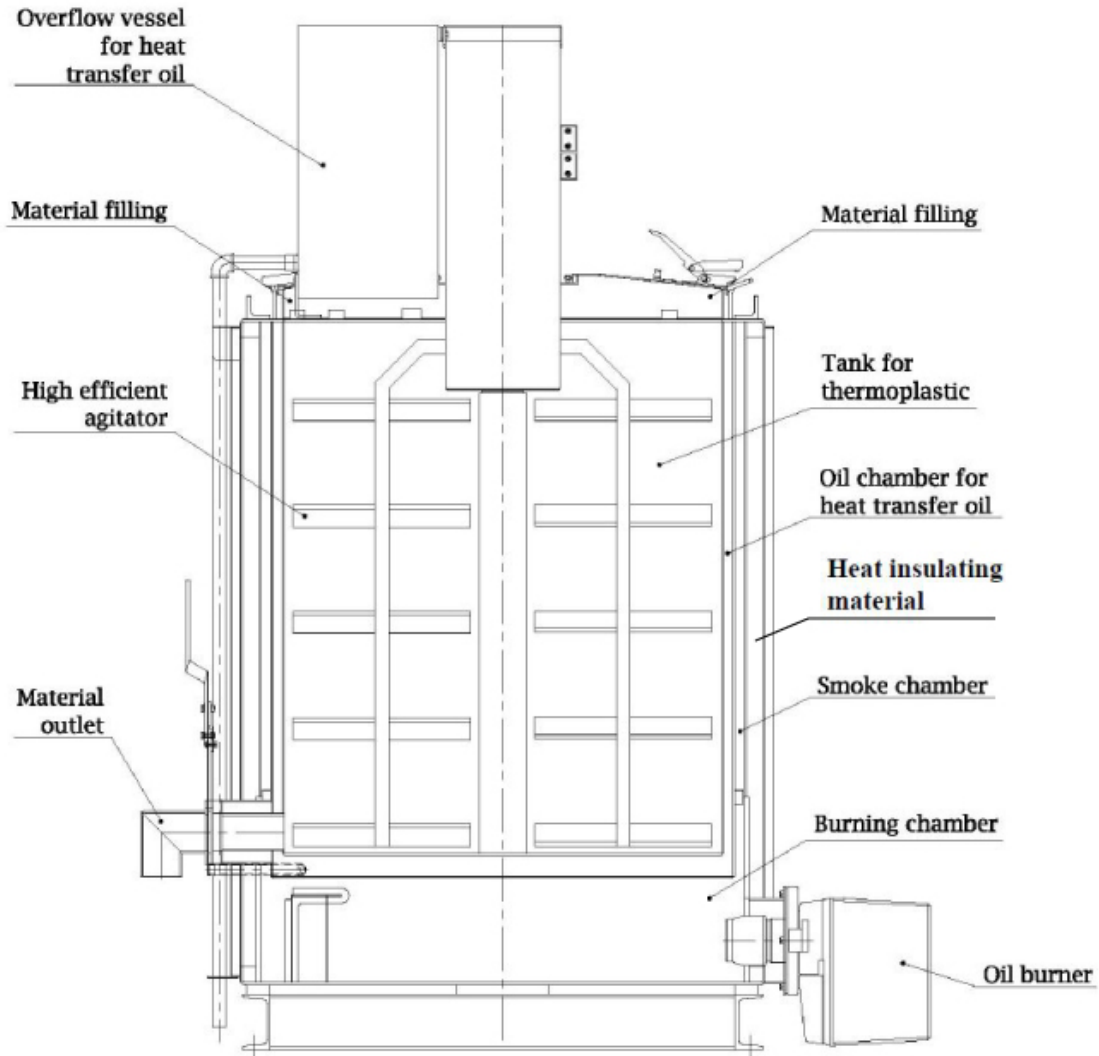

ADVANTAGES

- Better thermal control secures a gentle handling of the thermoplastic material, which ensures optimal application conditions in the temperature working area – maximum heating without risk of material damage
- Safe heating conditions via the uniform heat distribution from the thermal oil
- Uniform storage temperature in all parts of the preheater – no hot spots
- Longer lifetime of the preheater due to the more gentle heat supply from the burner – no overheating of the steel parts

DIRECT HEATING

The thermoplastic material is heated directly from the burner, which is placed at the bottom of the preheater. Therefore, the heating of the thermoplastic material is done from this one location - the bottom of the preheater. This is different compared to the indirect system where the heating of the thermoplastic material is done from various angles due to the thermal transfer oil found in the oil chambers surrounding the preheater.

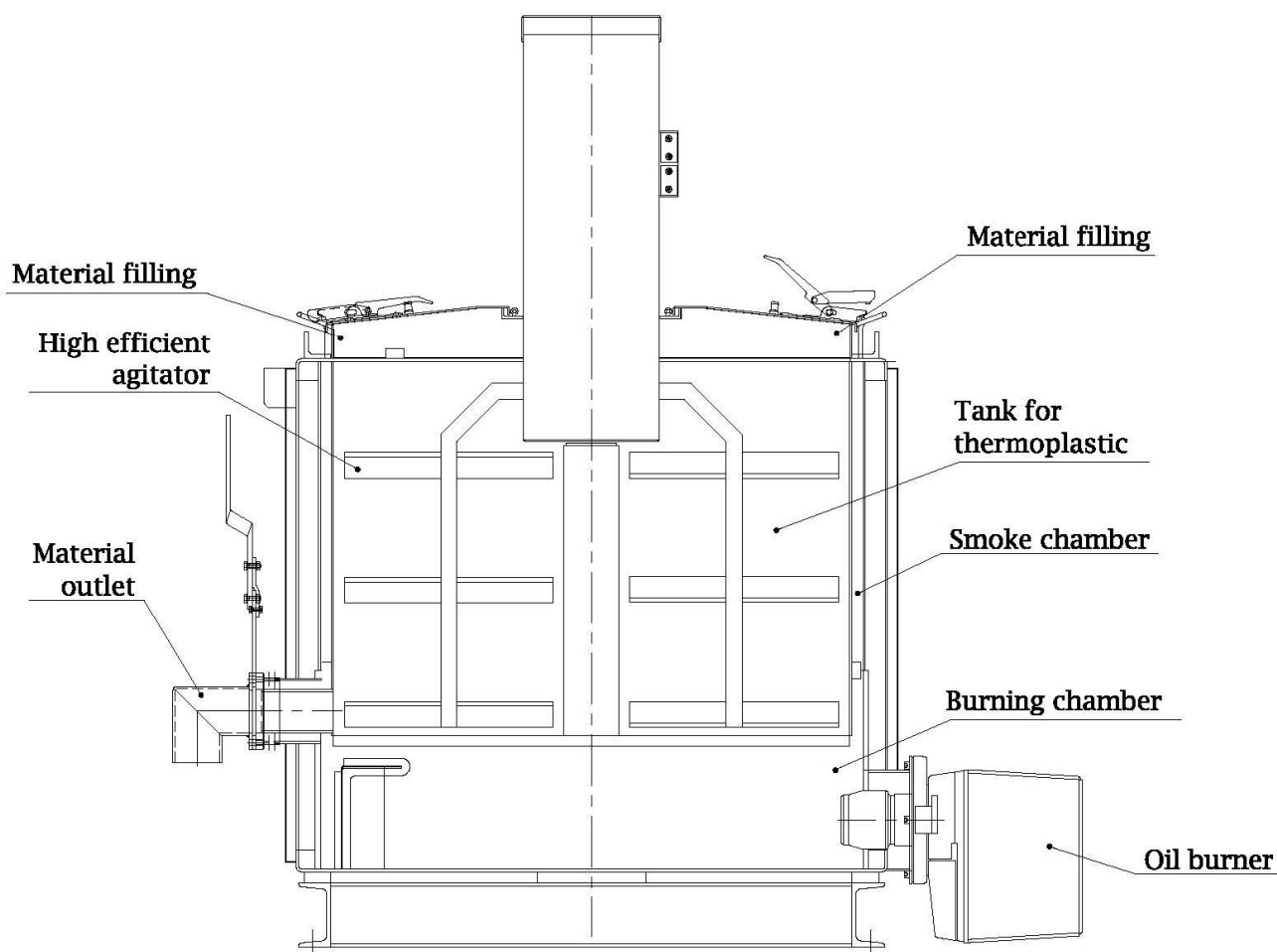

ADVANTAGES

- Quick heating time; the burner needs only to heat the steel of the preheater – no thermal oil as an in-between medium
- Higher melting capacity; more effect can be heated into the preheater, which then heats and melts the thermoplastic
- Simple construction – no thermal oil reservoir is build into the construction
- Lower cost price due to the more simple construction

HIGH-SPEED AGITATOR AND MIXING ARMS



Both the direct and indirect preheaters are equipped with the high-speed agitator and mixing arms, which ensures a perfect mixing of the thermoplastic. The agitator is capable to turn both clock wise (CW) and counter-clockwise (CCW).

As an option, it is possible to mount an automatic reversing agitator on the preheater with variable speed. With this option, it is possible to rotate the agitator slowly when the solid bags with thermoplastic are filled into the preheater and gradually increase the speed as they melt.

The automatic reversing agitator can be set to run CW e.g. 60 seconds, then 5-second pause, then again 15 seconds CCW; this will be repeated continuously when the agitator is set on automatic. Such automatic cycle sequences are a major benefit to uniform the thermoplastic when being melted.

TIPS FOR CORRECT PREHEATER USE, MAINTENANCE & MELTING TEMPERATURE

It is a good idea NOT to keep an empty or low material level in the preheater when the preheater is turned on. If the preheater is running for multiple hours while having a low material level, the walls of the preheater can get affected.

At longer breaks in the application work, it is recommended to decrease the temperature at all thermoplastic thermostats, or you can completely turn off the oil burner and keep an eye on the temperature.

